



What happened to IPMulticast?

RIPE 50

Stockholm, Sweden

Greg Shepherd

shep@cisco.com

Agenda change..

Treehouse/Suspension Bridge Engineering



Agenda



- **What happened to IPMulticast?**

- *Is it still alive?*
- *Where?*
- *Who's using it and why?*
- *What are their biggest challenges today?*
- *Why has it not been deployed as rapidly as we all hoped..or
Why don't I have it at home?*
- *Is the dream of global multicast deployment still alive?*
- *If so, what are the current barriers to deployment today?*
- *Does it have a future?*

What happened to IPMulticast?



- **A question with a past...**
 - *Steve Deering*
 - *Making a routed network look like a LAN*
 - *Global MBONE built with DVMRP tunnels*
 - *Hub-and-spoke*
 - *Early applications were conferencing tools*
 - *Vic, Vat, WB, SDR*
 - *Some early "visionaries" pinned-up radio stations*
 - *Source discovery was expected of the network*

MBONE evolution...



- Central DVMRP global architecture
 - *MBONE – a flat world*
- MBGP/PIM transit – preMSDP
- MSDP/MBGP/PIM-SM

MBONE - the world is flat



DVMRP tunnels to a central router.

The Internet

A flat world.

From site routers or from local hosts running mrouterd.

Nice testing ground, but not much more than a toy.

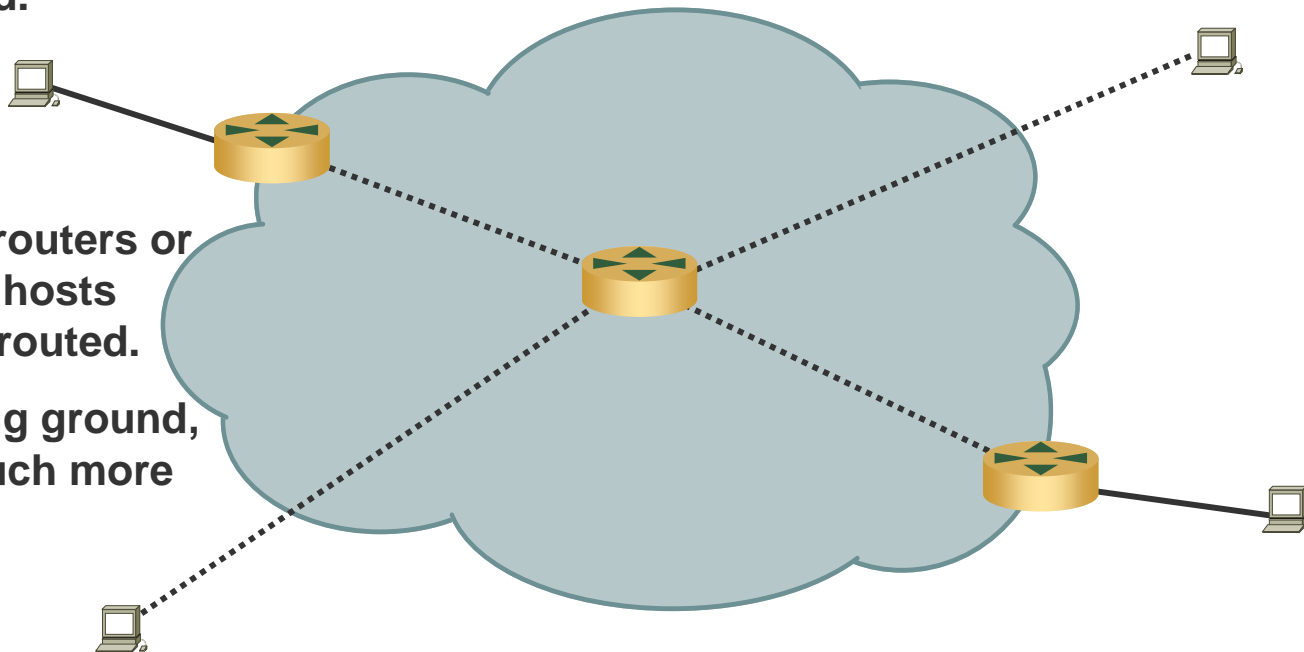

“Hey, this is like running RIP across the Internet!” – yep!

NoBone MBGP/PIM transit – preMSDP



Legacy MBONE DVMRP tunnels

The first MIX

Each ISP running PIM-SM internally.

Full mesh of MBGP peering across the L2 exchange.

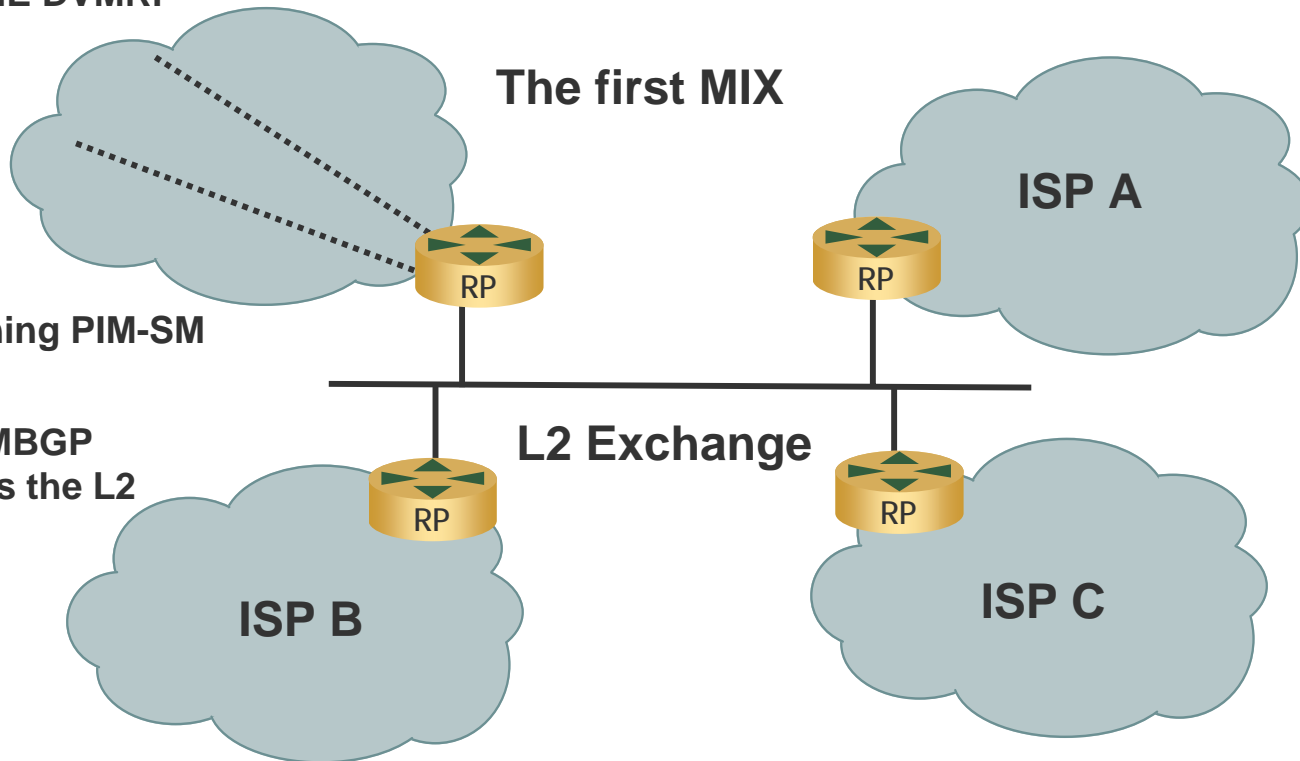

BUT, RPs MUST be on the exchange, and PIM-DM run on the MIX interfaces to flood S,G info to all other RPs

NoBone MSDP/MBGP/PIM-SM – Today.. Well 1999/2000

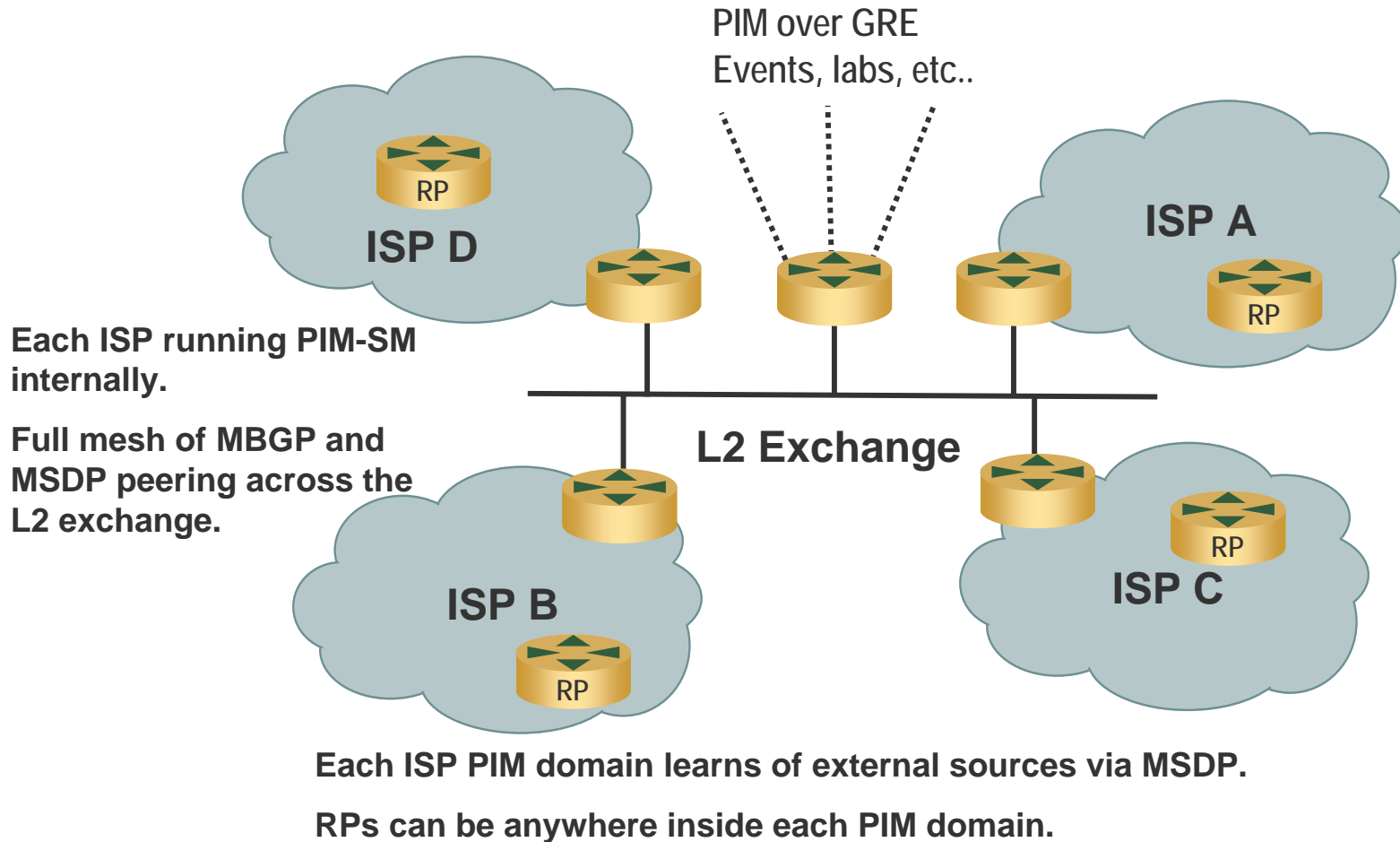

NoBone

MSDP/MBGP/PIM-SM – Today.. Well 1999/2000



We're done!

WRONG

What's Wrong?



- **Multicast in the Internet is an all-or-nothing solution**
 - *EVERY ROUTER on EARTH needs to be mcast enabled. *sigh**
- **Even Mcast-aware content owners resorted to unicast streams to gain audience size**
 - *Broadcast.com - early visionaries, too early.*
- **Unicast doesn't scale**
 - *Splitters/Caches just distribute the problem*
 - *Still has a cost-per-user*
 - *As receiver BW increases, problem gets worse.*
 - *Creates a non-functional business model*
 - *Maybe we need a new business model*

Meanwhile...



..while the Internet Multicast Peacemakers were holding hands at a drum circle dreaming of global multicast deployment, working late-nights helping engineers around the world turn-on PIM and turn-up multicast transit and peering, and listening to classical music from Oregon with Vat...

Multicast was being deployed!

Islands of deployment



- **Financial Networks**
 - *Security Exchanges*
 - *NASDAQ, NYSE, AMSE, HKSE, etc..*
 - *Securities Trading Enterprises*
- **Enterprises**
- **Service Providers**
 - *MVPNs*
 - *Walled-Gardens*
 - *DSL, Cable*

How? Security Exchanges



End-to-end in control (mostly...)

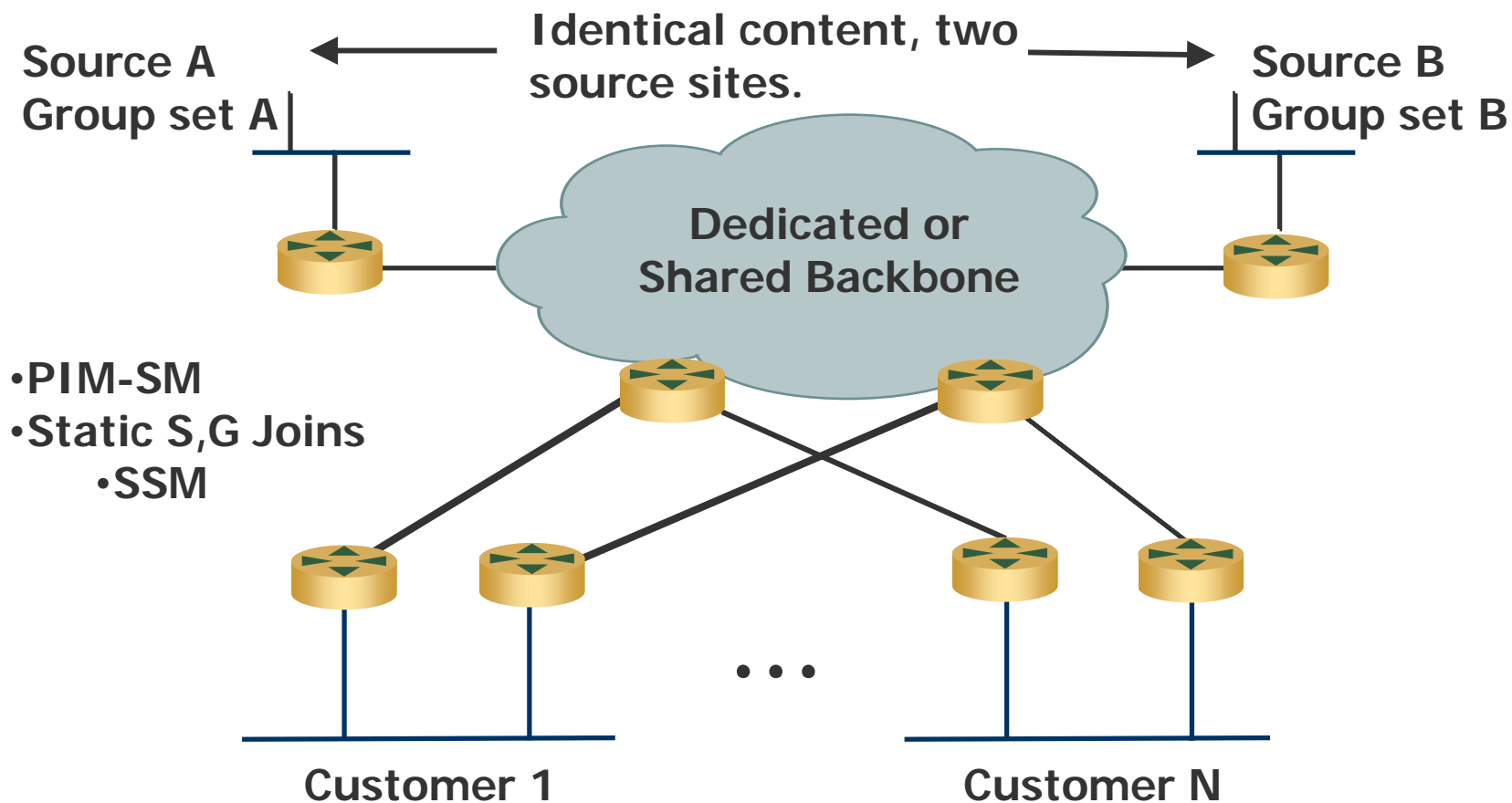

How? Security Trading Enterprises



End-to-end in control

- PIM-SM
 - BiDir-PIM
- Anycast-RP
 - MSDP
- Tuned PIM Hello-interval
- Needs FAST convergence

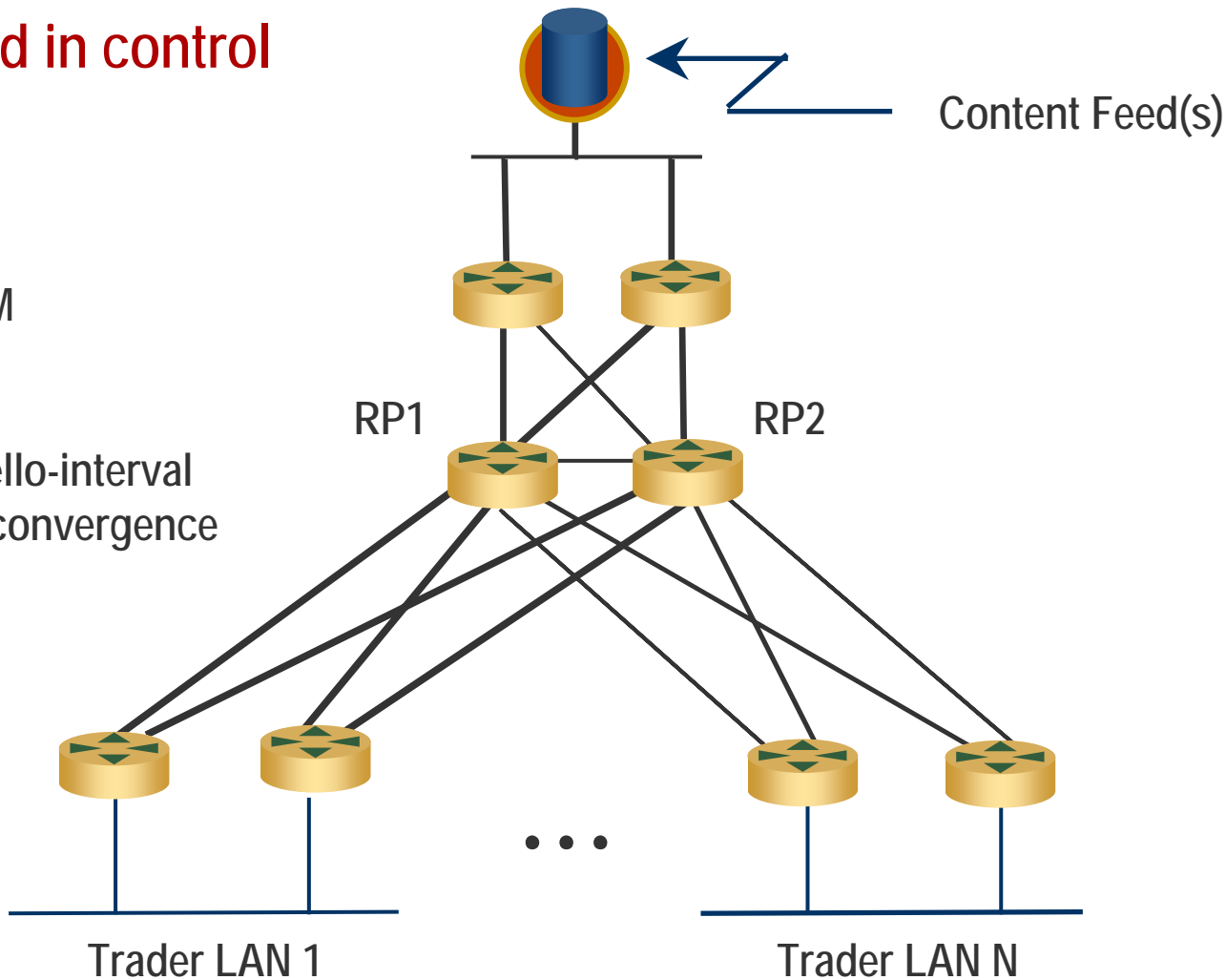

Security Trading Enterprises Phase I



PIM-SM

Redundant RPs at the core

Anycast-RP via MSDP

State Requirements:

$(S) \times (G) + 1$ for all routers
in the path.

$(S) \times (G)$ for content LAN
routers

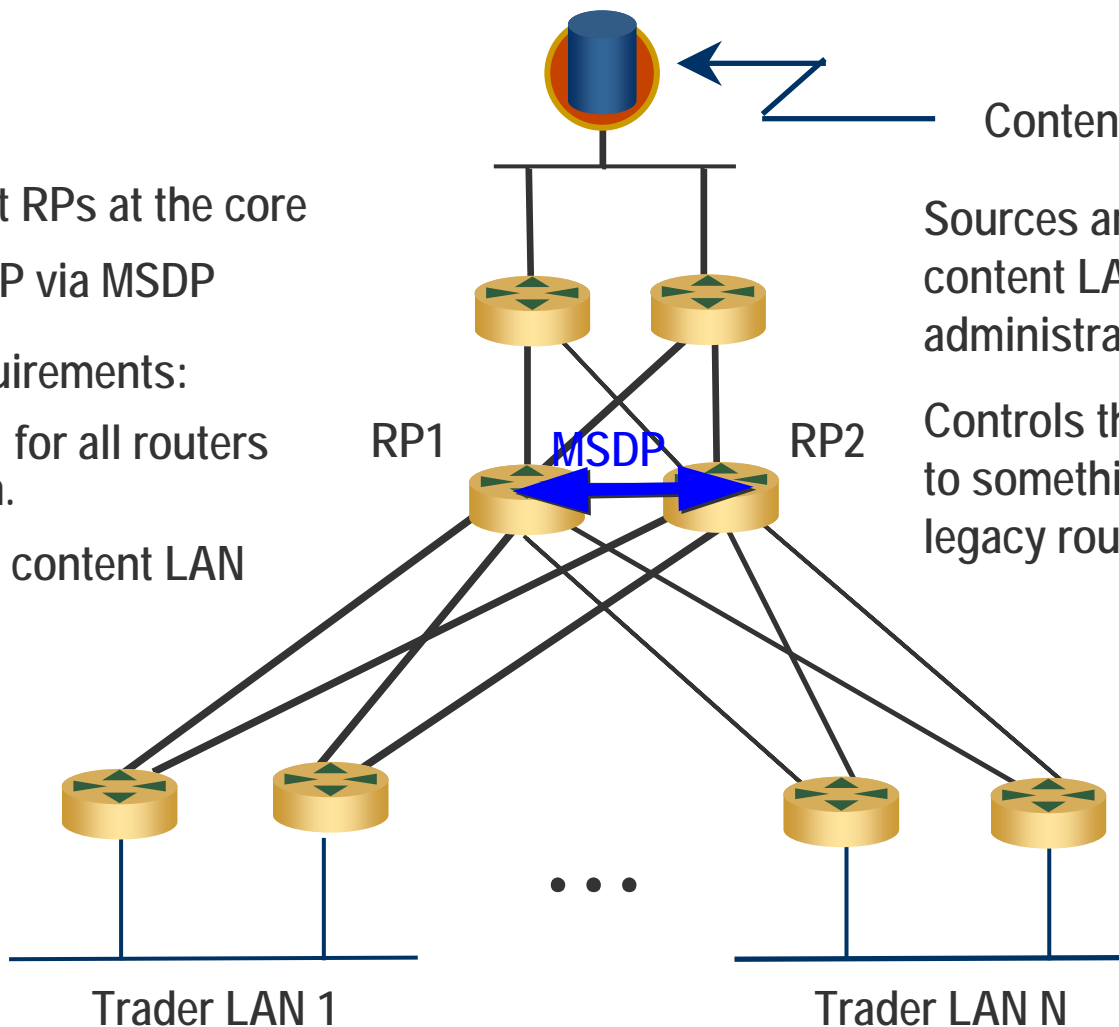

Content Feed(s)

Sources are confined to the
content LAN, and G is
administratively controlled.

Controls the amount of state
to something manageable in
legacy routers.

Security Trading Enterprises Phase II



PIM-SM

Redundant RPs at each
content LAN (multiple
content LANS)

Anycast-RP via MSDP

SPT threshold infinity = (*,G)
forwarding

State Requirements:

$(S_L) \times (G) + 1$ for all content
routers in the path.

G for other routers in the
path

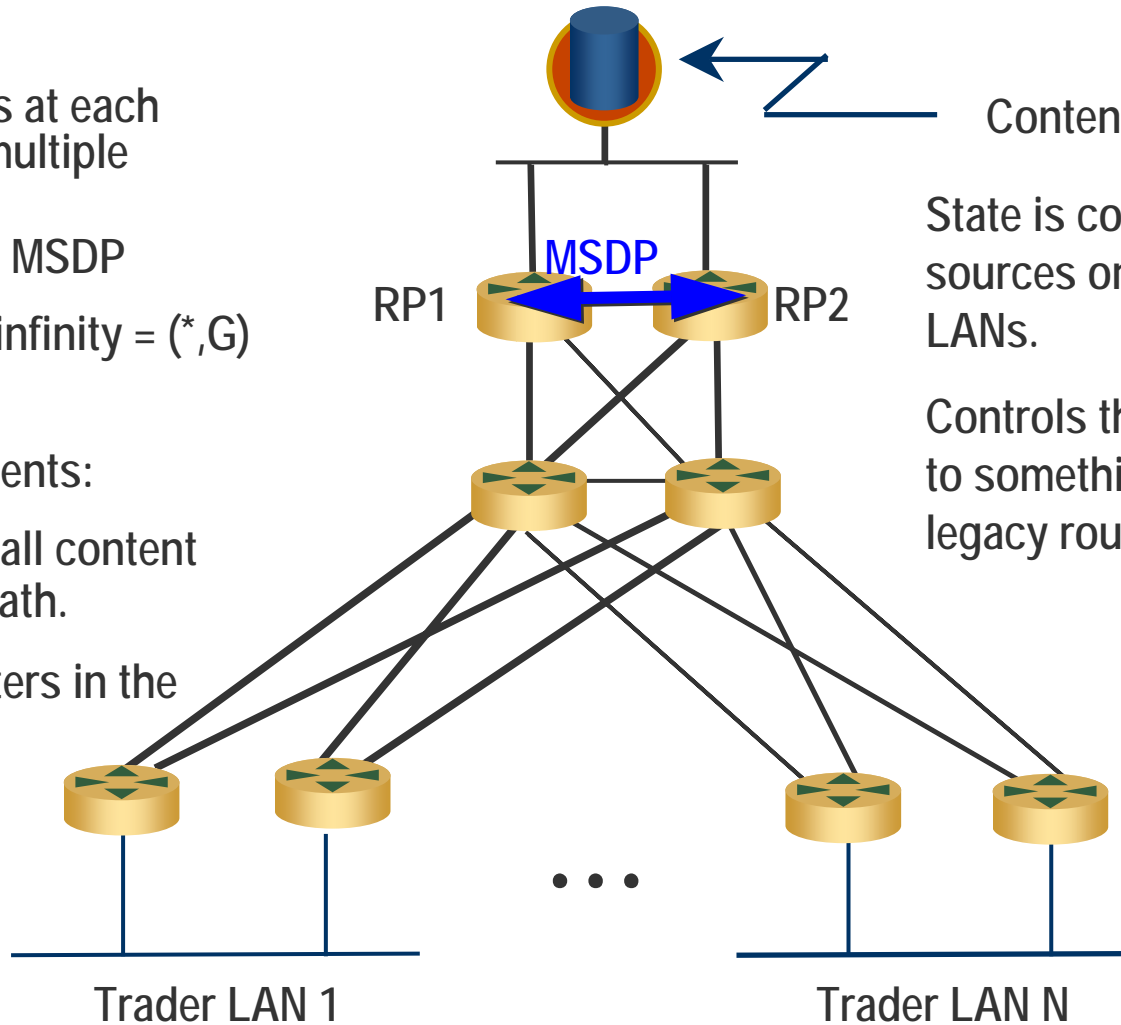

Content Feed(s)

State is controlled by splitting
sources onto separate content
LANs.

Controls the amount of state
to something manageable in
legacy routers.

Convergence Time tightly coupled to mroute state

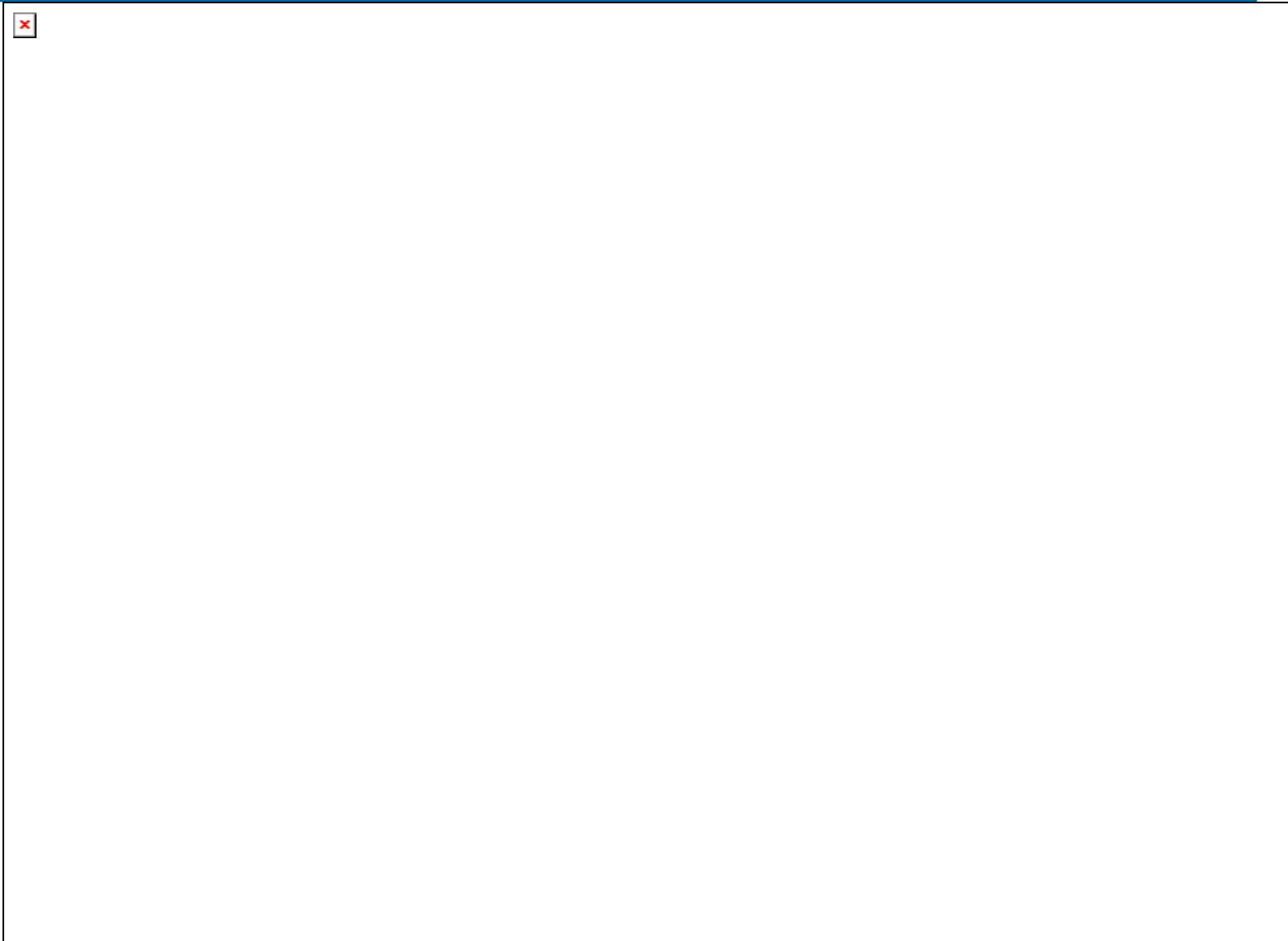

Security Trading Enterprises Phase III



BiDir PIM

Redundant RPs at the core –
one primary, one secondary
as per configuration

State Requirements:

G for all routers in the
path

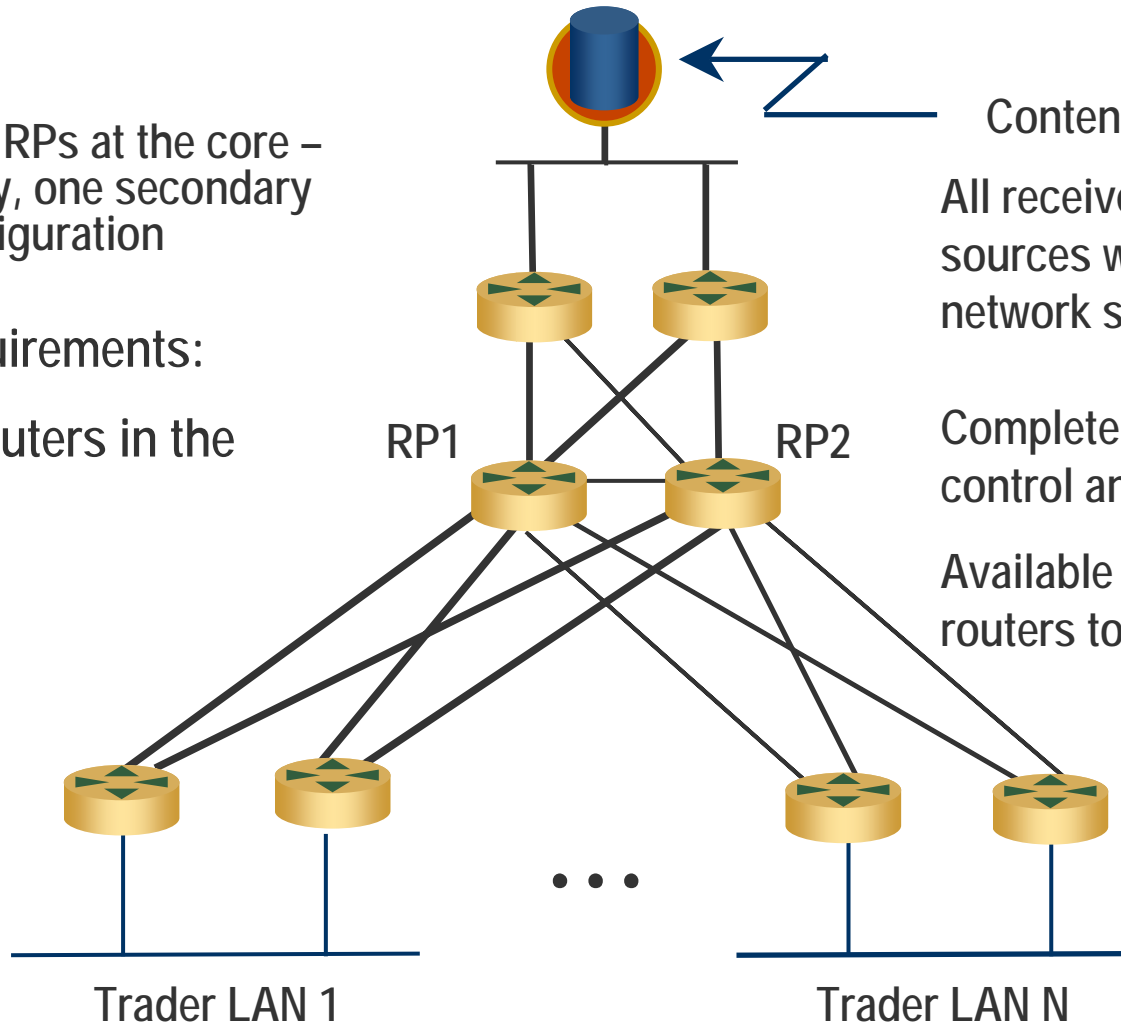

Content Feed(s)

All receivers can also be
sources with no impact on
network state requirements

Complete separation of
control and data plane

Available in high-performance
routers today

How? Enterprises



End-to-end in control

- PIM-SM internally
- Scoped local content
- Scoped WAN content
- PIM-SM/MSDP/MBGP transit peering
- WMP, QT, Real, IPTV

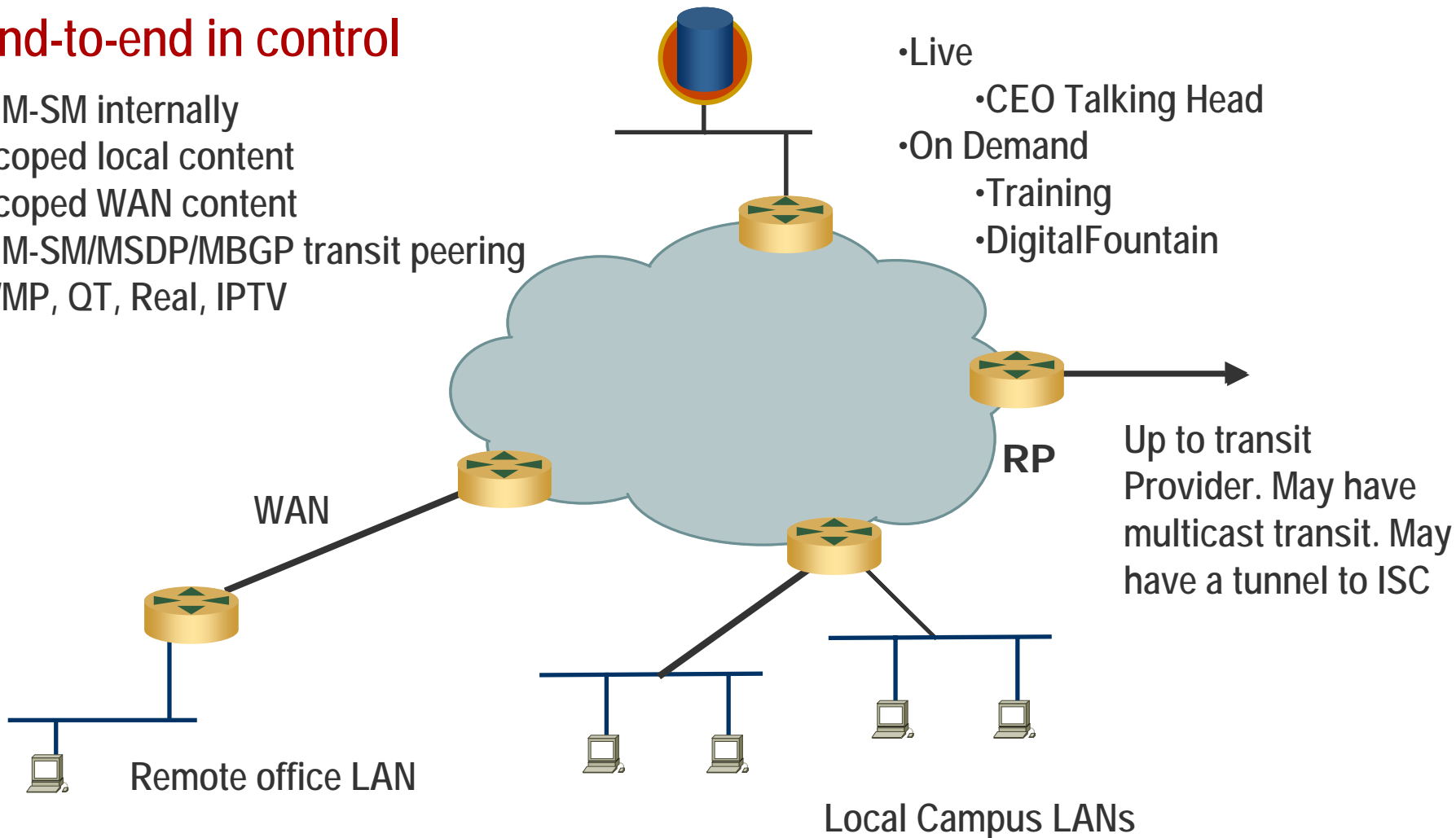

How?

Service Providers (IP)



Internal control only

- PIM-SM internally
 - One PIM domain
- Anycast-RP
 - MSDP mesh/peer group

- May have sourcing policy
- Some content
- Peering with ISC :)

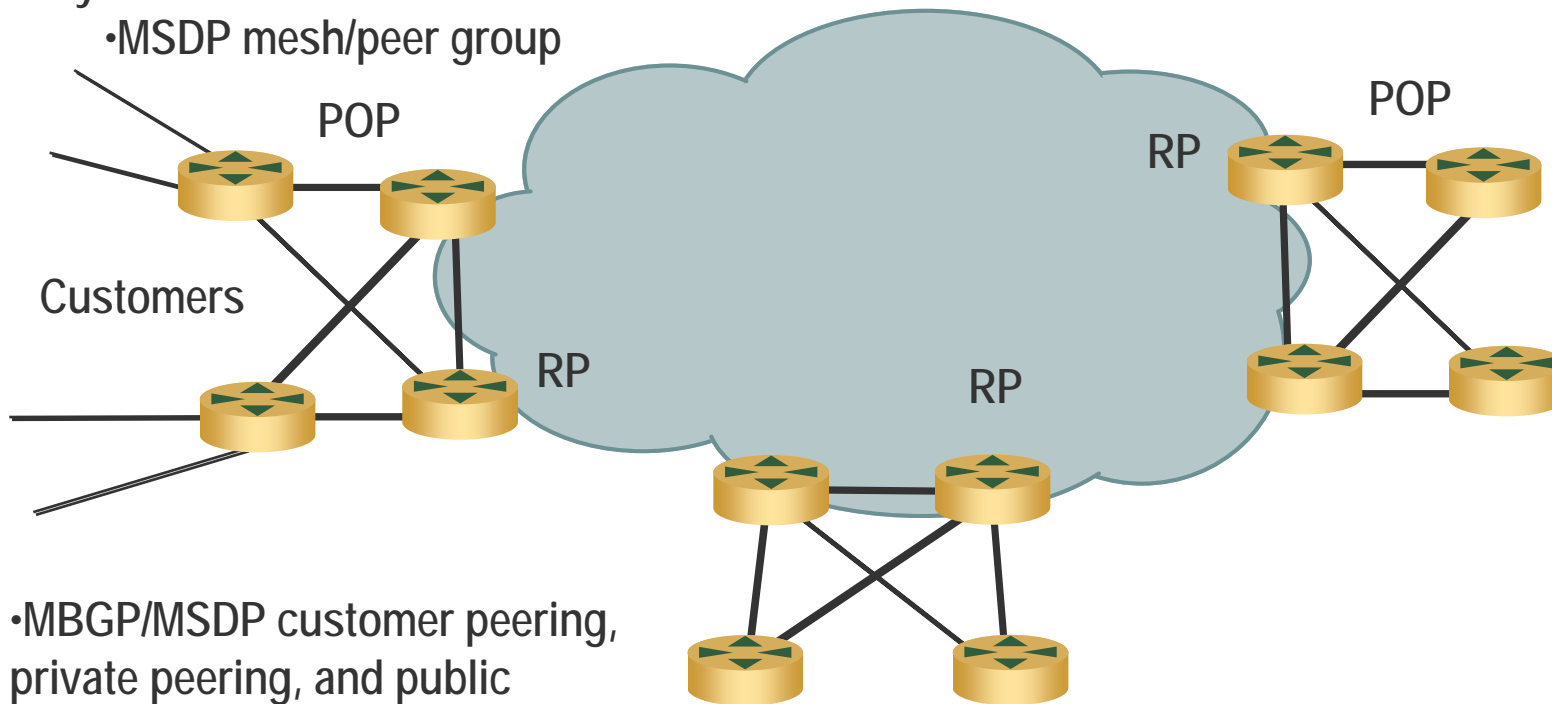

- MBGP/MSDP customer peering, private peering, and public exchange.

Content Service Networks Cable/DSL

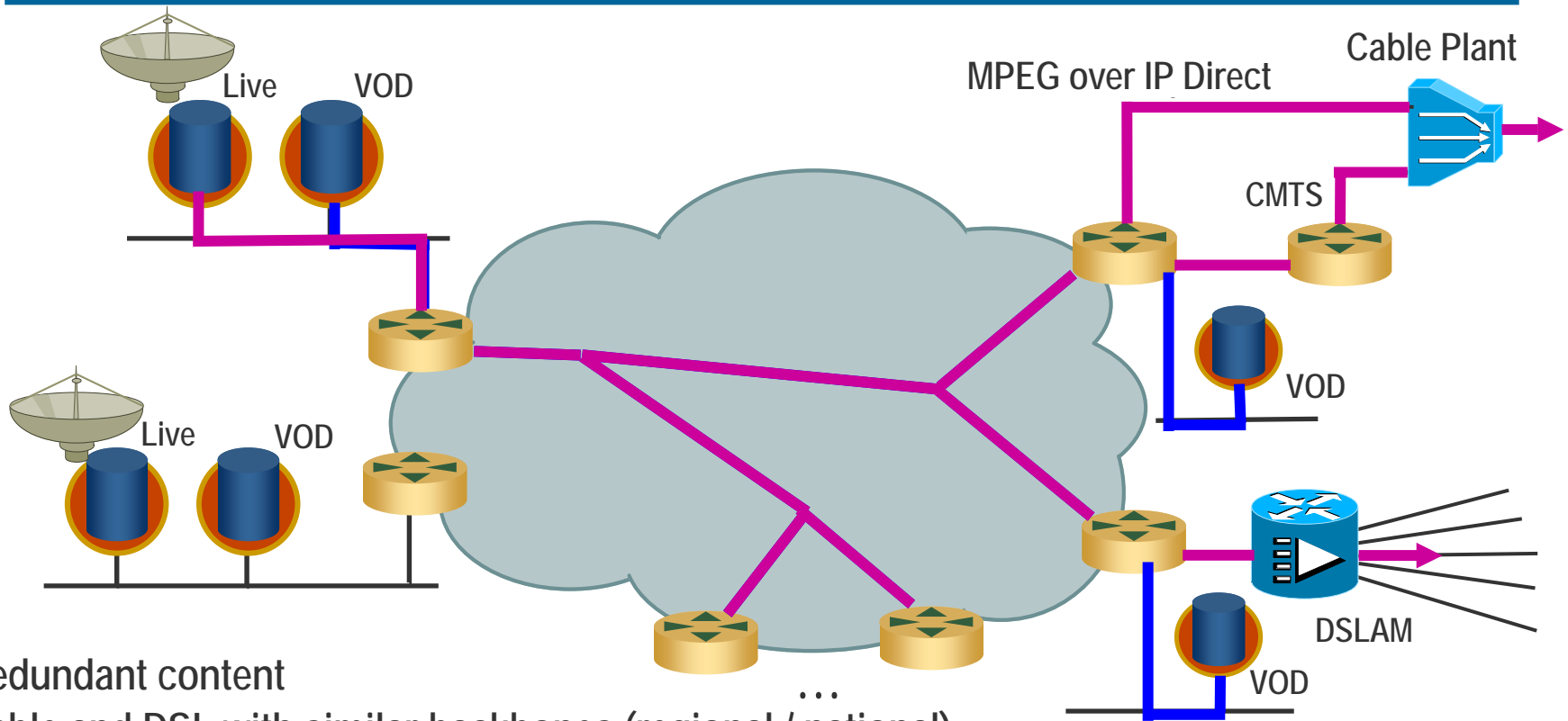

- Redundant content
- Cable and DSL with similar backbones (regional / national)
- Numerous customer aggregation sites
- Populate local VOD servers via multicast over the backbone
- Live video over IP Multicast

How?

VPN Providers – Rosen opt2 (2547)



Internal control only

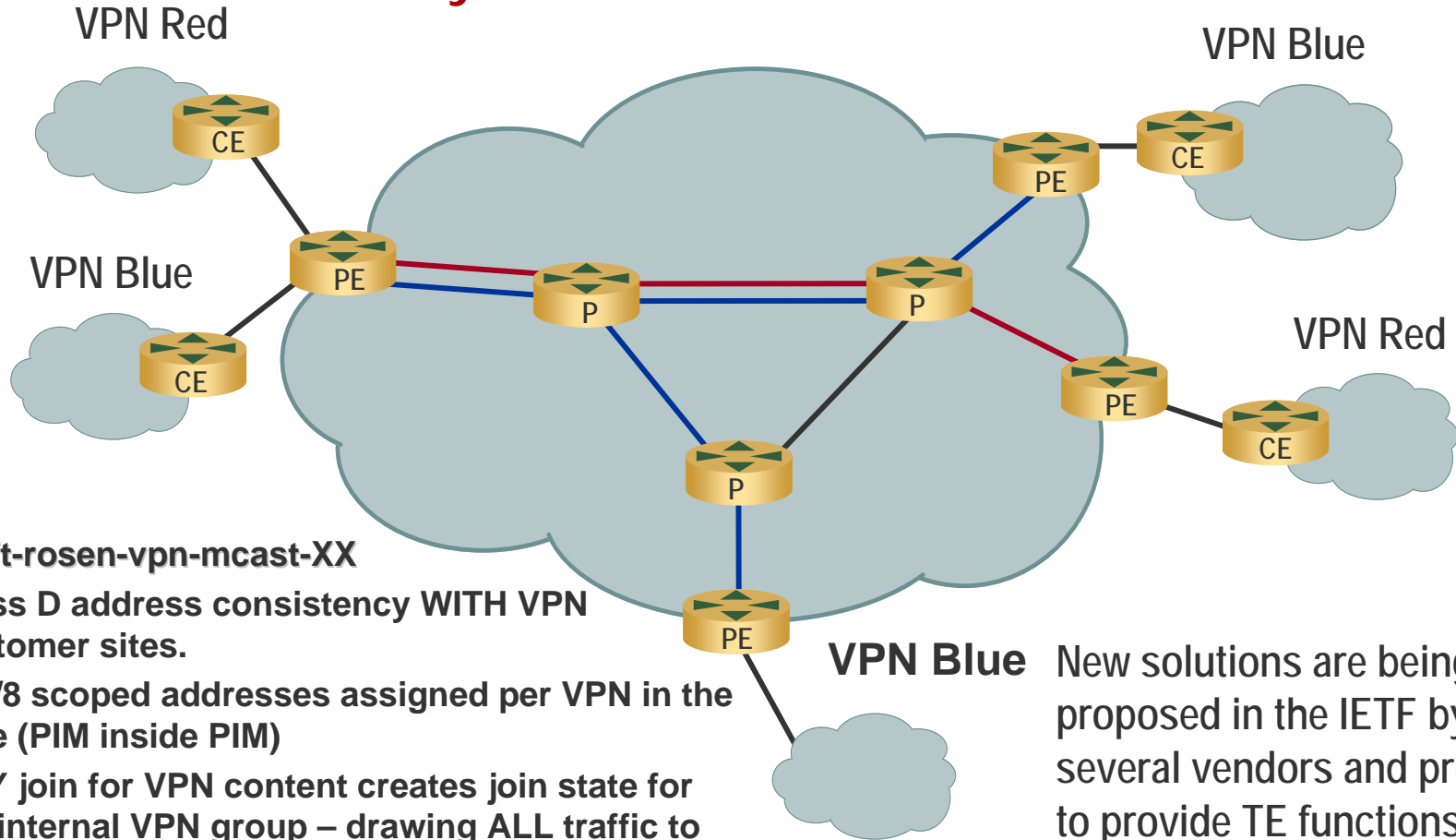

draft-rosen-vpn-mcast-XX

Class D address consistency WITH VPN customer sites.

239/8 scoped addresses assigned per VPN in the core (PIM inside PIM)

ANY join for VPN content creates join state for the internal VPN group – drawing ALL traffic to the PE. Unwanted group traffic (once decap'd by the PE) must be dropped.

VPN Blue New solutions are being proposed in the IETF by several vendors and providers to provide TE functions for MVPNs.

But what happened to the dream?



- ISC Multicast Project
- Mroute Aggregation Network
- Multicast.isc.org

ISC Multicast Project

What?



- **Mroute aggregation network**
 - *Routers at EQX, PAIX, ORIX, 200 Paul*
 - *Transit tunnels to other IX routers in Italy, Germany, Asia*
- **Native peering at MIXs**
- **Direct P2P transit/peering**
- **Transit tunnels to remote MIXs**
- **Transit tunnels for remote networks**
 - *Campus, office, lab, edge networks, content networks*
- **Transit tunnels for events (NANOG, IETF, etc)**
- **Configuration assistance, troubleshooting, training**
 - *<http://www.nsrc.org>*

ISC Multicast Project

Why?



- Internet Multicast Peacemakers are still out there
- Multicast is still not ubiquitous
- Promote connectivity in support of interests, applications, and content
- “updated MBONE” to encourage continued usefulness of MCAST
- Develop multicast services at remote IXs
- Sandbox for new multicast solutions

ISC Multicast Project

How?



- **Native L2 peering (transit) at the MIXs**
 - *EQX, PAIX, FIXW, ORIX, 200 Paul*
 - *PIM, MBGP, MSDP*
- **PNI peering / transit**
- **Tunnels**
 - *Remote IXs, networks, and events*
 - *GRE, IPIP*
- **Remote RP services**
- **Default route for receiver-only networks**

ISC Multicast Project

Success example



- **USP (Brazil)**

- *Campus eng contacts me for transit tunnel*
- *Assist with config, and campus mcast deployment planning*
- *Local content sourcing, receiver application testing*
- *Help set requirements for upstream provider*
- *Upstream turns-up native transit in SE US.*
- *USP Campus rolls over to native upstream transit*
- *Tunnel is turned down*

ISC Multicast Project

Some coolness



- 5900 prefixes today
- 25 peers
- 600 PIM joined streams
- **ISC has the largest mcast footprint (prefixes)**
 - *True global transit service offering*
- **Bitrate**
 - *Background: 5-10Mbps*
 - *Peak: 40Mbps*
 - *Internet2 raw HDTV streams becoming available*
- **Production-dependent connectors today**
- **AUP-free access to Internet2 content and connectors**

ISC Multicast Project Future



- Peering / transit always available
- Looking for
 - *More holes to fill*
 - *More islands to bridge*
 - *Interesting content, applications, solutions, etc*
- M6Bone
- AMT – auto-tunnels – Last Mile Solution (the missing piece)
 - *draft-ietf-mboned-auto-multicast-xx*
- Is Multicast Growing?
 - *YES – but from the edges-in*
 - *Large walled-garden projects worldwide*

ISC Multicast Project

Thanks to all who have helped!!



Cisco
DigitalFountain
EQX
ISC
Juniper
NASA / FIXW
ORIX / UofO
PAIX / S&D
Procket
Sprint
Verio



Going Forward...



So what's right and wrong with multicast today?
What's being done to fix it?

What Worked?

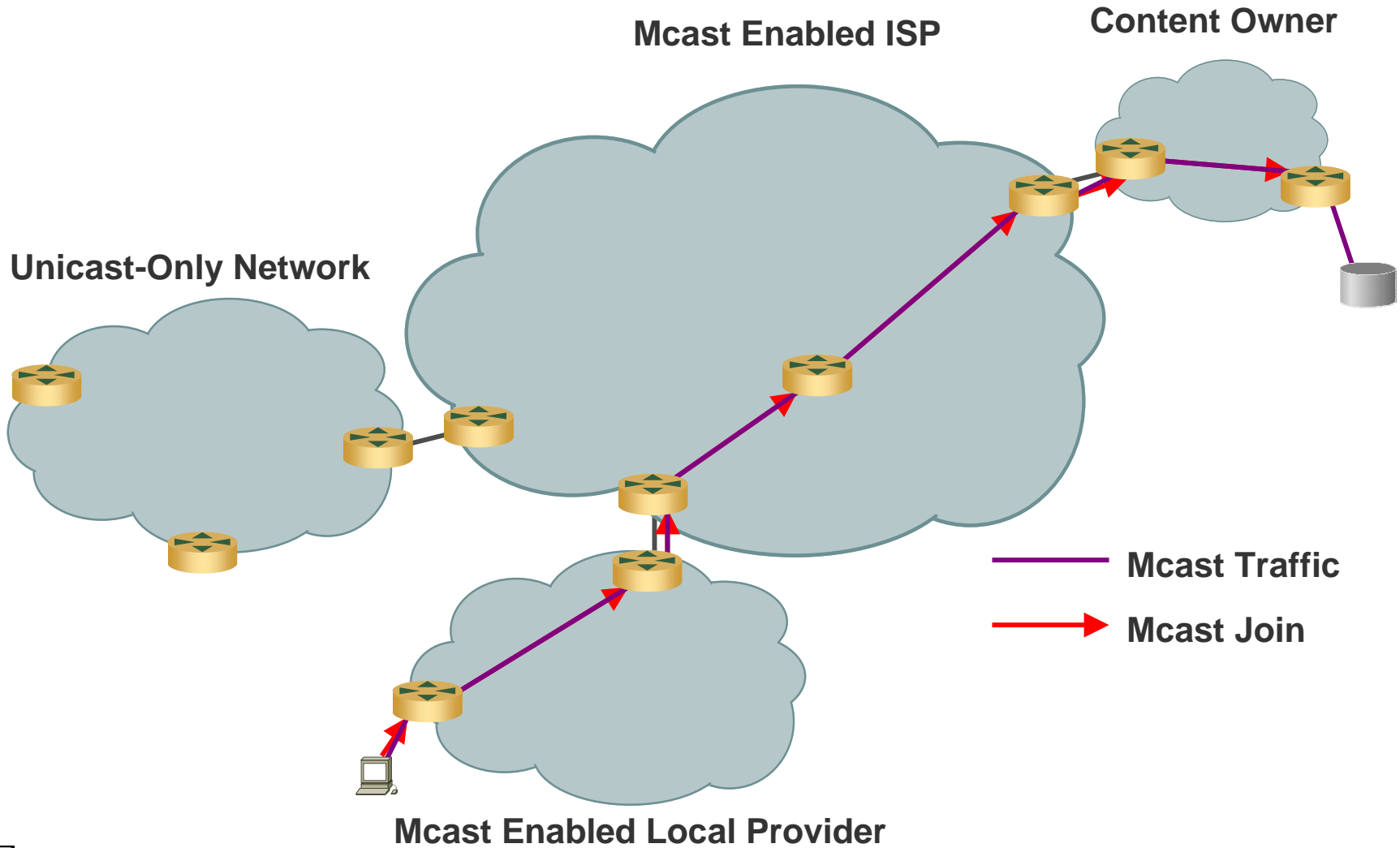

What Worked?

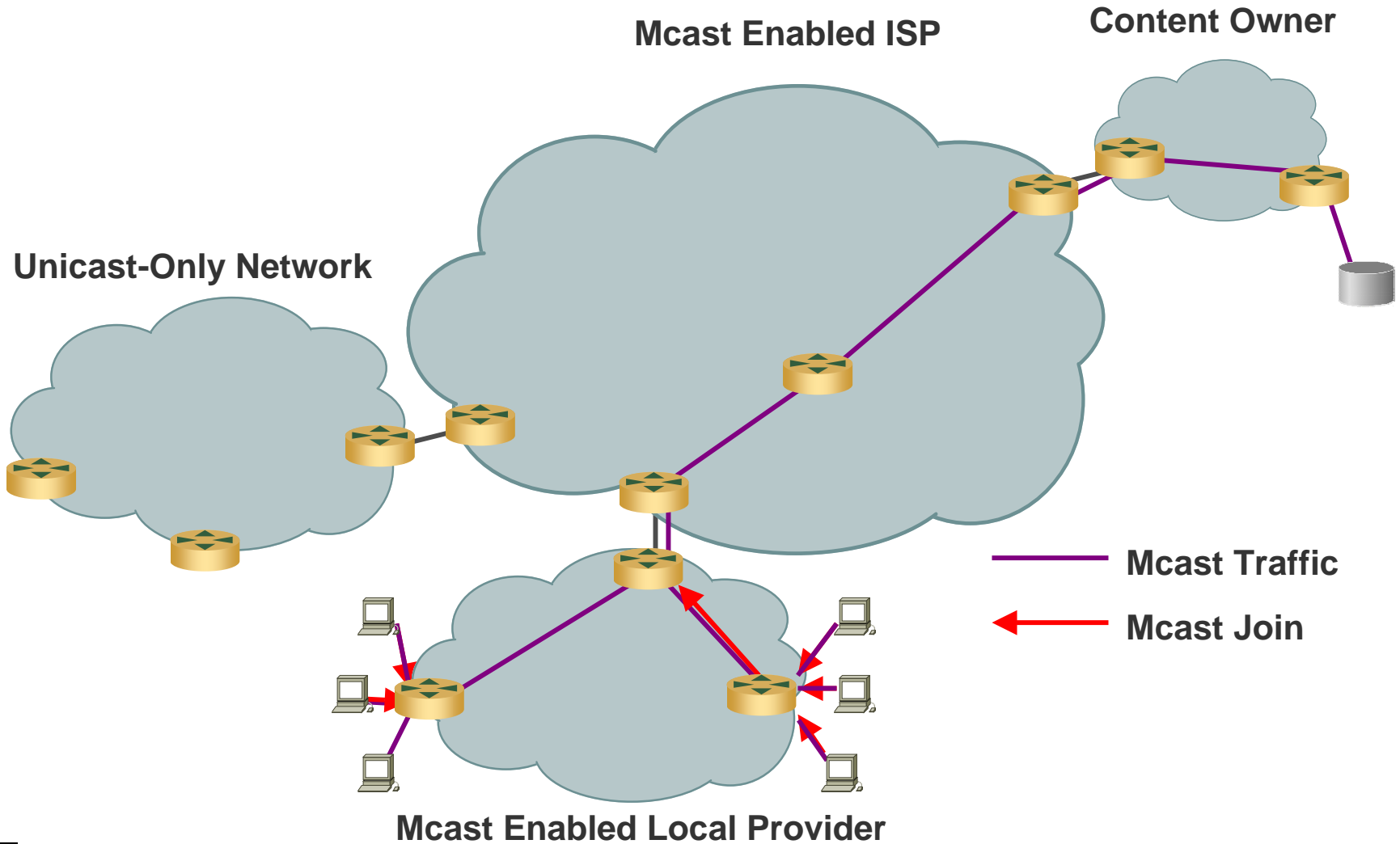

What Worked?

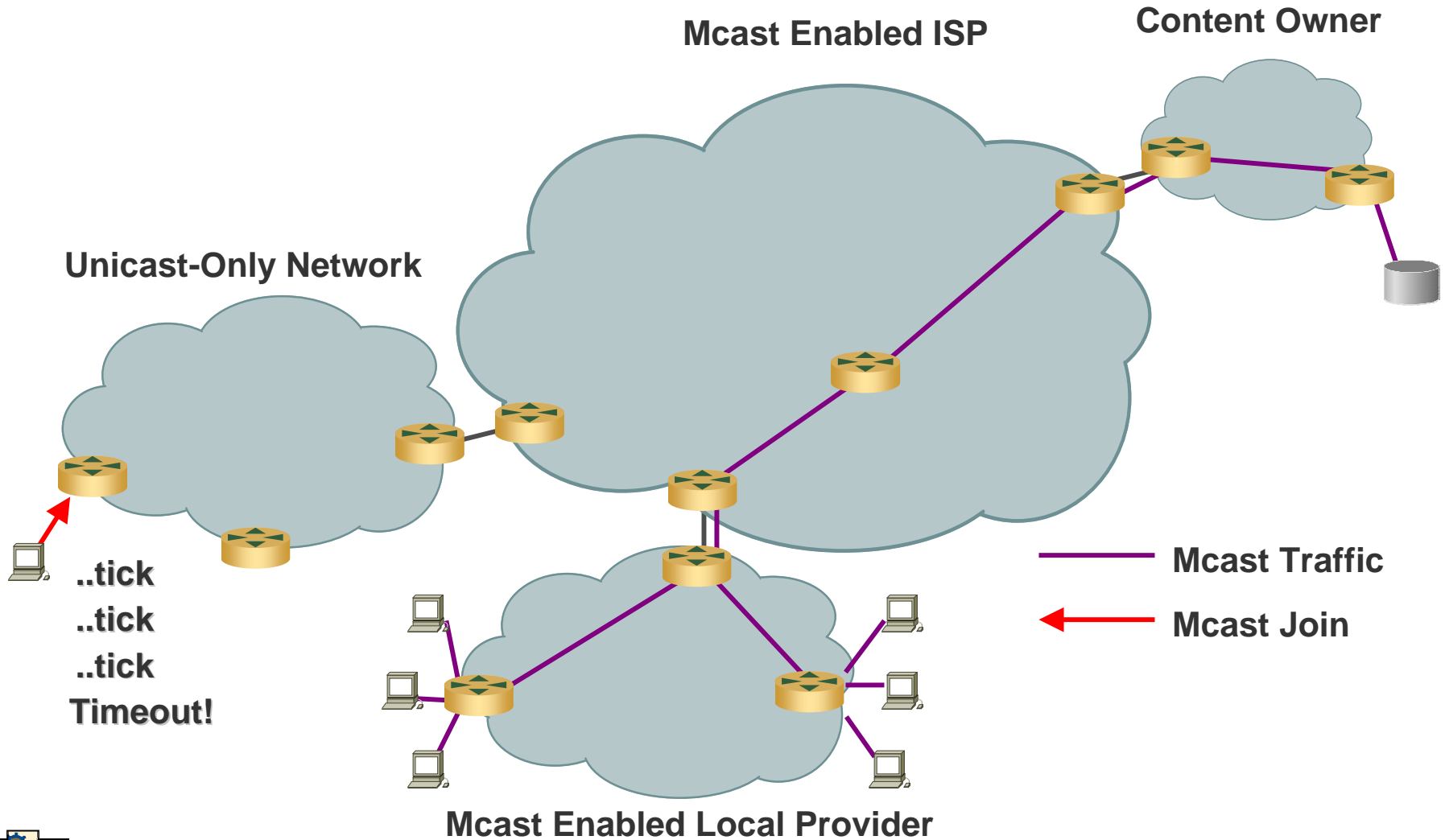

What Didn't?

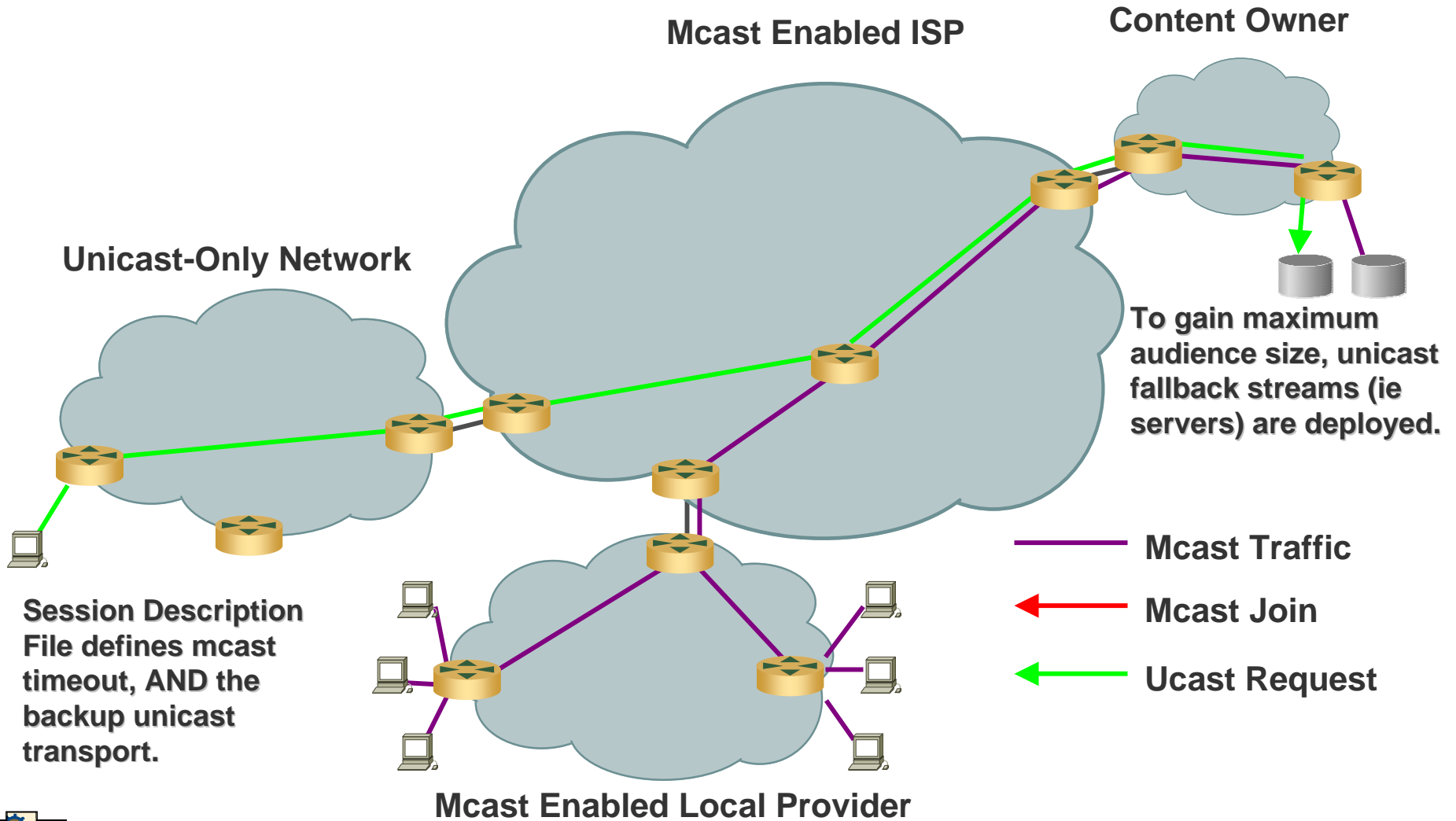

What Didn't?

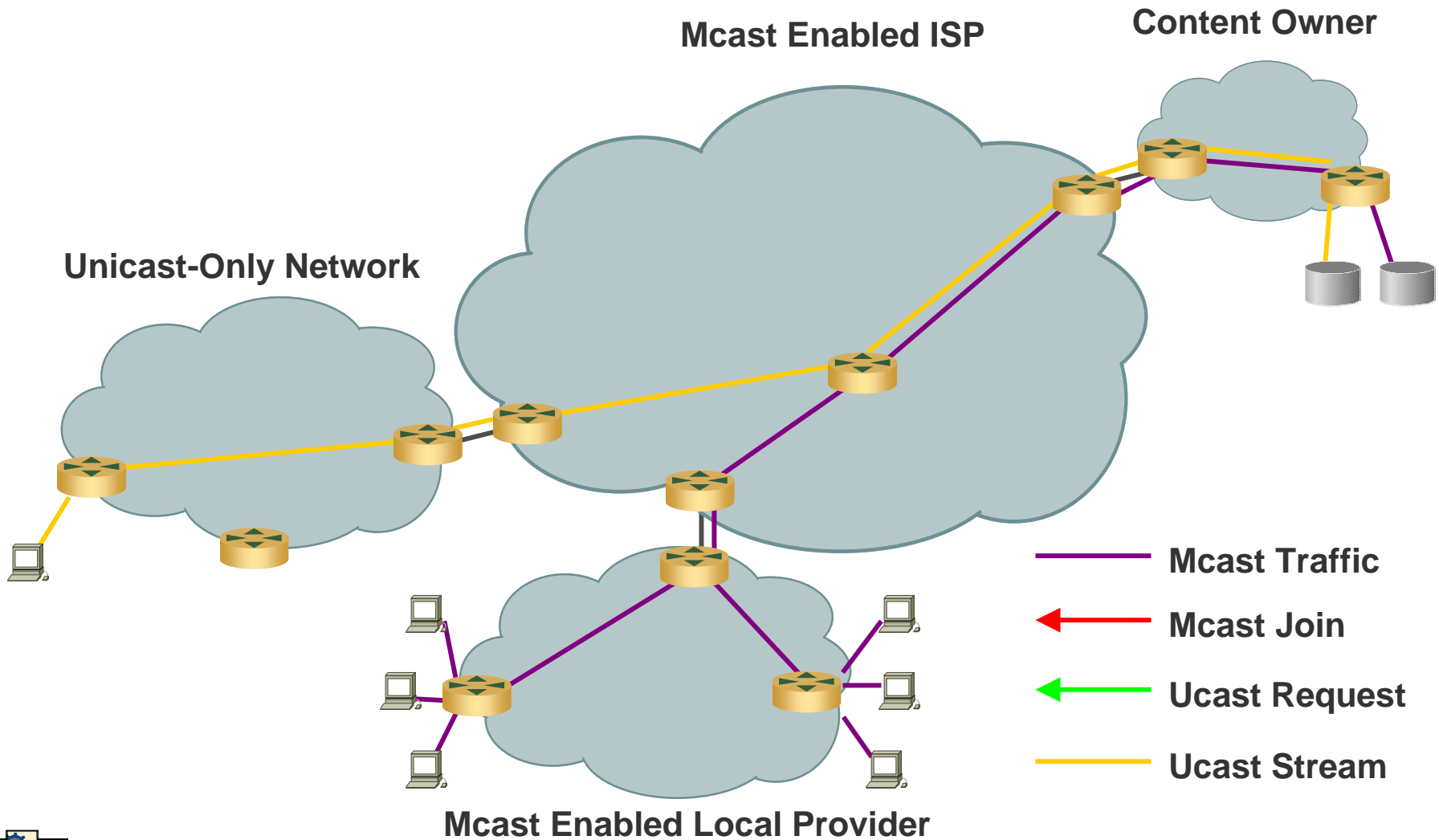

What's Wrong?

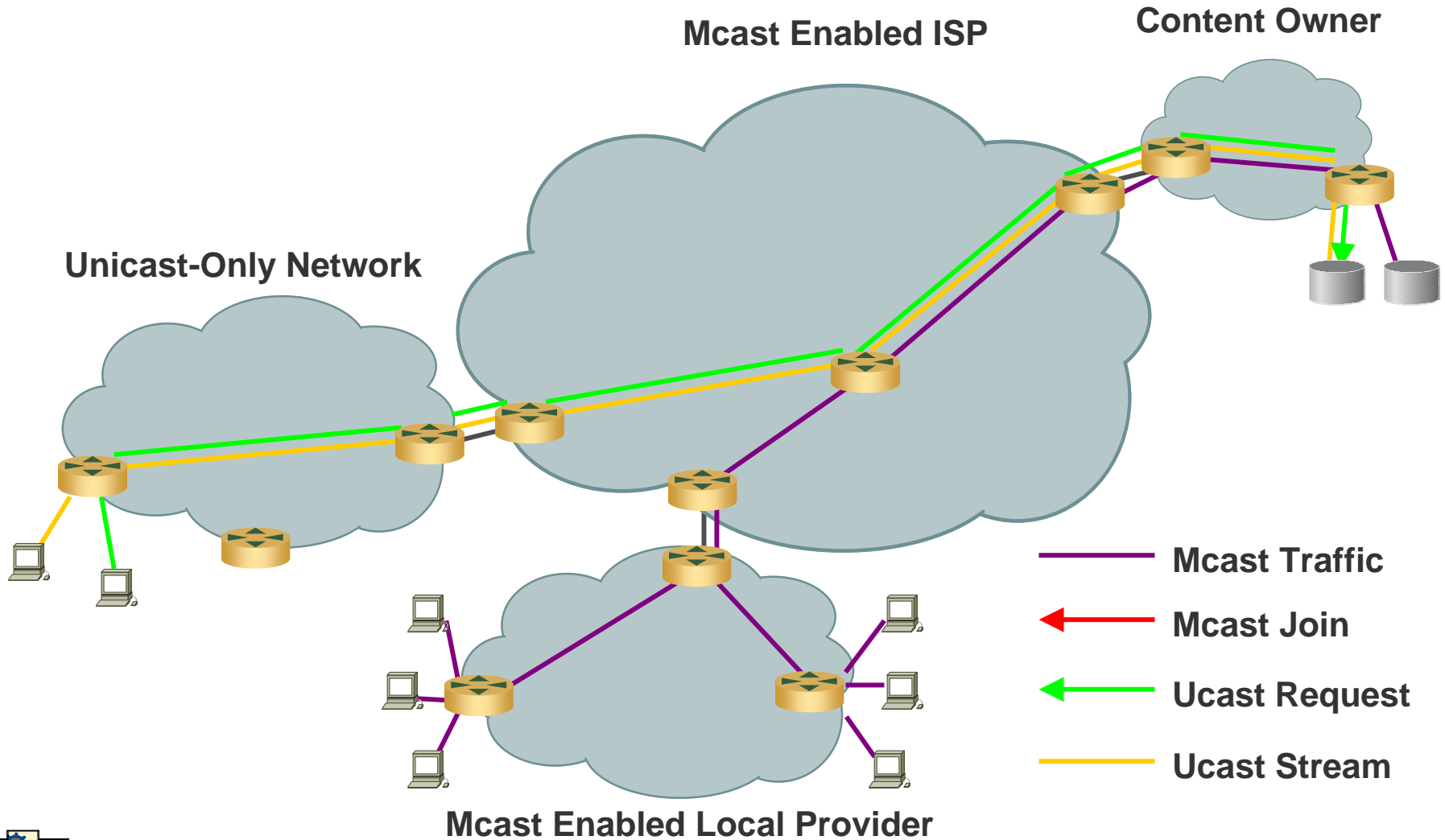

What's Wrong?

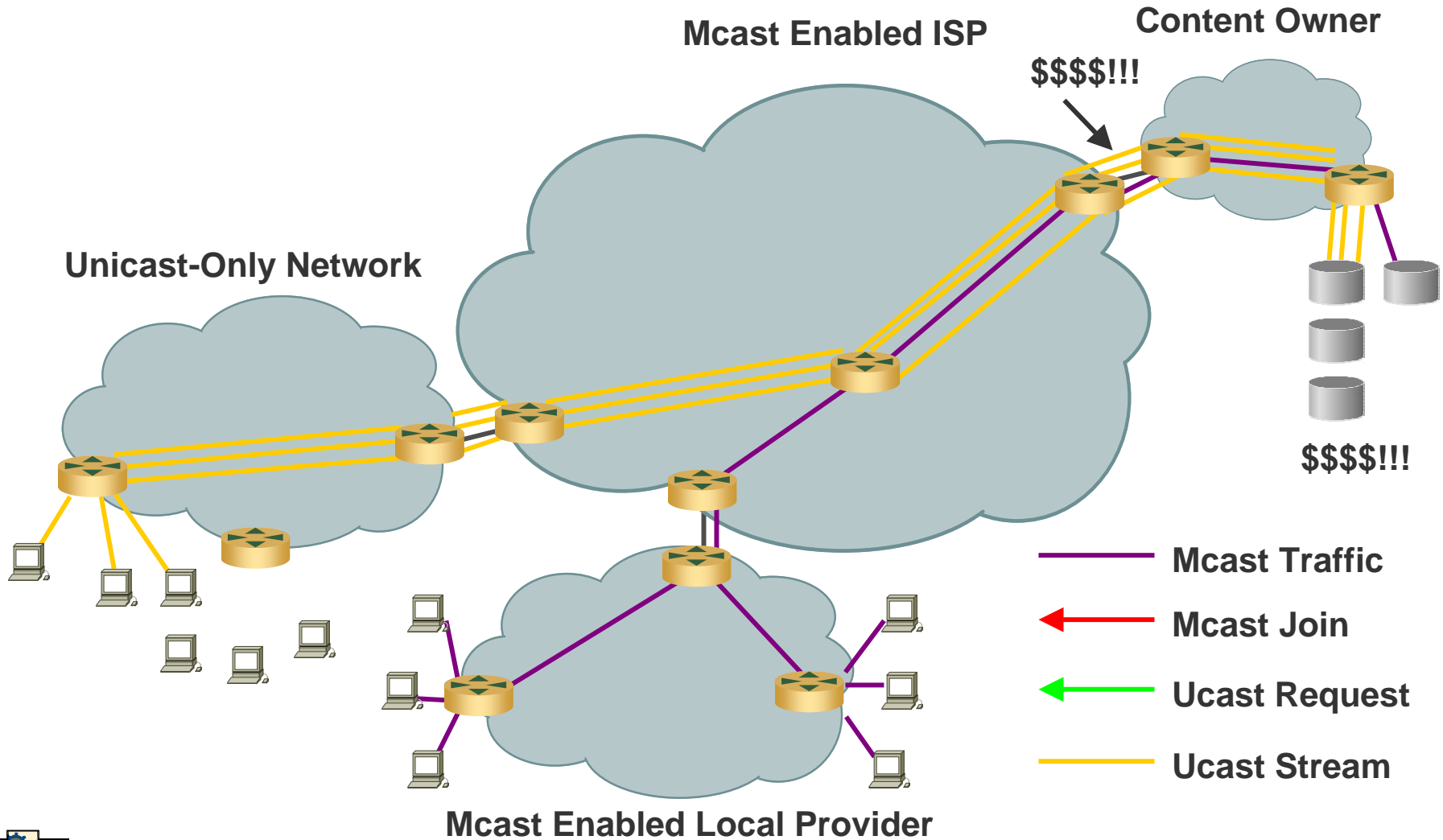

What's Wrong?



- Multicast in the Internet is an all-or-nothing solution
- Is there a way to provide a multicast-only solution for content owners?
- Do they really need multicast today for global distribution?

One Solution: AMT



(S,G) is learned from the AMT join request message, then (S,G) first PIM join is sent toward the source.

Mcast Enabled ISP

Content Owner

Unicast-Only Network



Mcast Enabled Local Provider



One Solution: AMT



AMT Router replicates stream on behalf of downstream AMT receiver, adding a unicast header destined to the receiver.

Mcast Enabled ISP

Content Owner

Unicast-Only Network

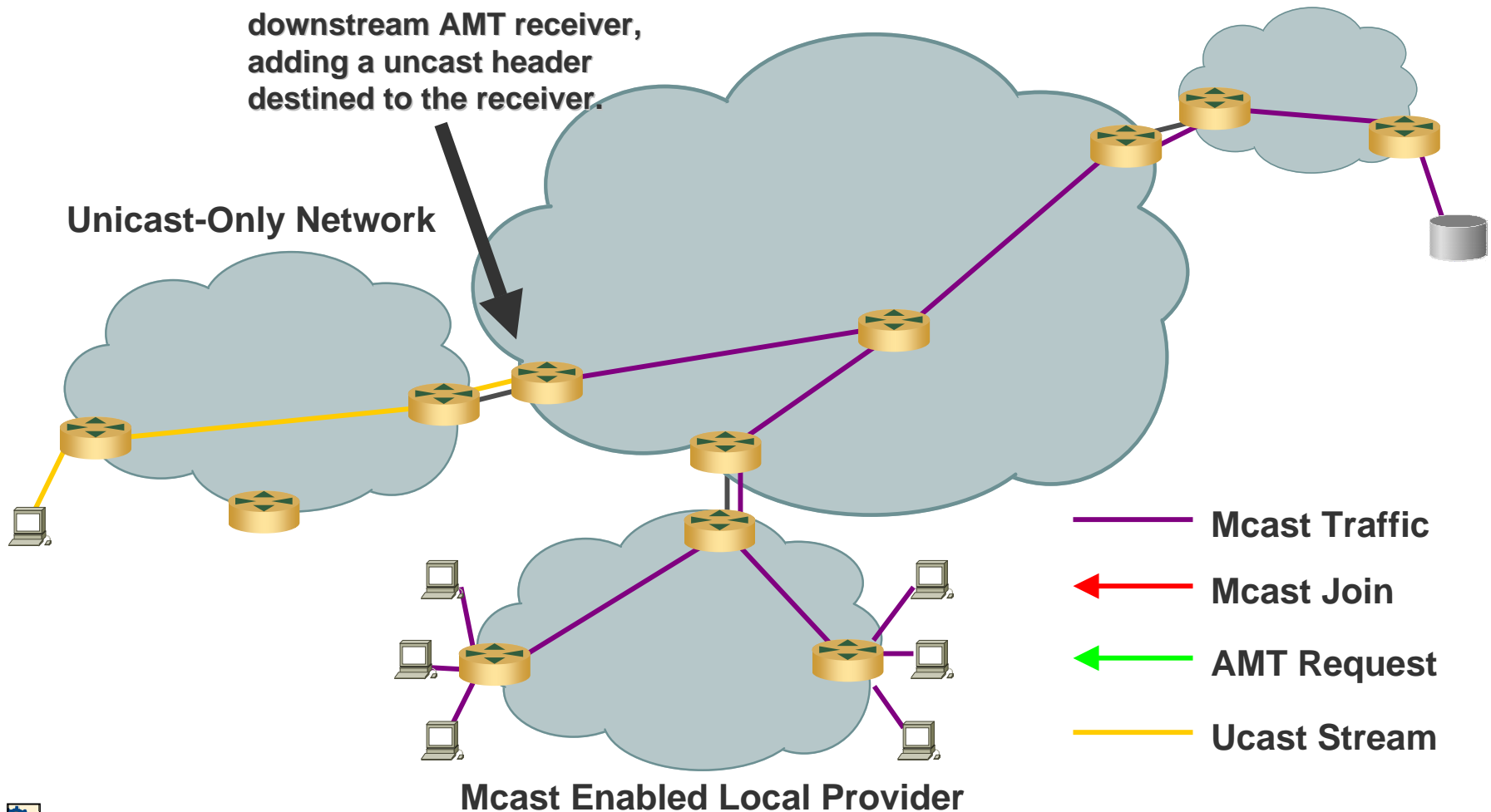

- Mcast Traffic
- ← Mcast Join
- ← AMT Request
- Ucast Stream

Mcast Enabled Local Provider



One Solution: AMT



Creates an expanding radius of incentive to deploy multicast.

Mcast Enabled ISP

Content Owner

Unicast-Only Network

Enables multicast content to a large (global) audience.

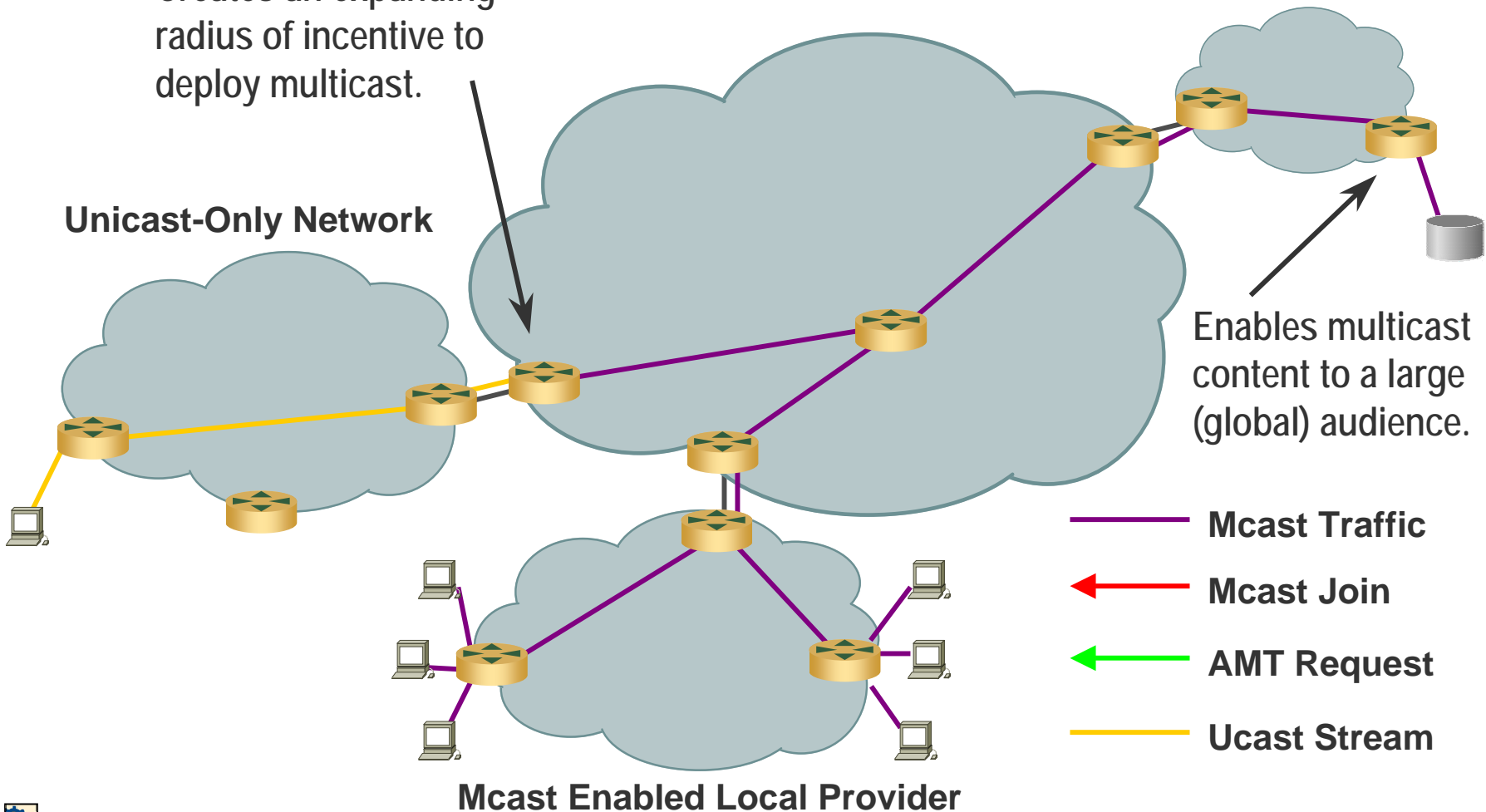

Mcast Enabled Local Provider

- Mcast Traffic
- ← Mcast Join
- ← AMT Request
- Ucast Stream



One Solution: AMT



Creates an expanding radius of incentive to deploy multicast.

Mcast Enabled ISP

Content Owner

Unicast-Only Network

Enables multicast content to a large (global) audience.

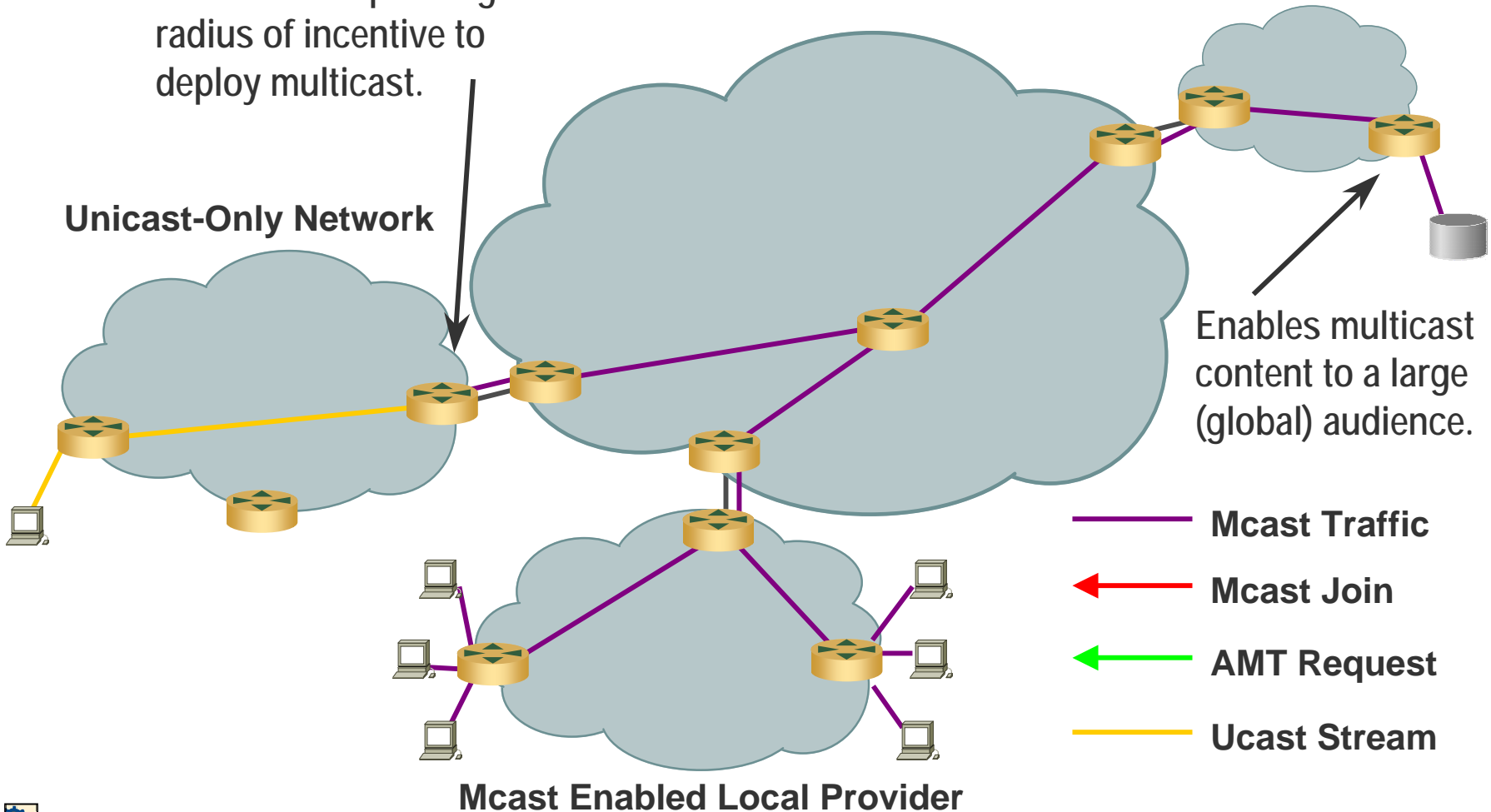

Mcast Enabled Local Provider

- Mcast Traffic
- ← Mcast Join
- ← AMT Request
- Ucast Stream

One Solution: AMT



Creates an expanding radius of incentive to deploy multicast.

Mcast Enabled ISP

Content Owner

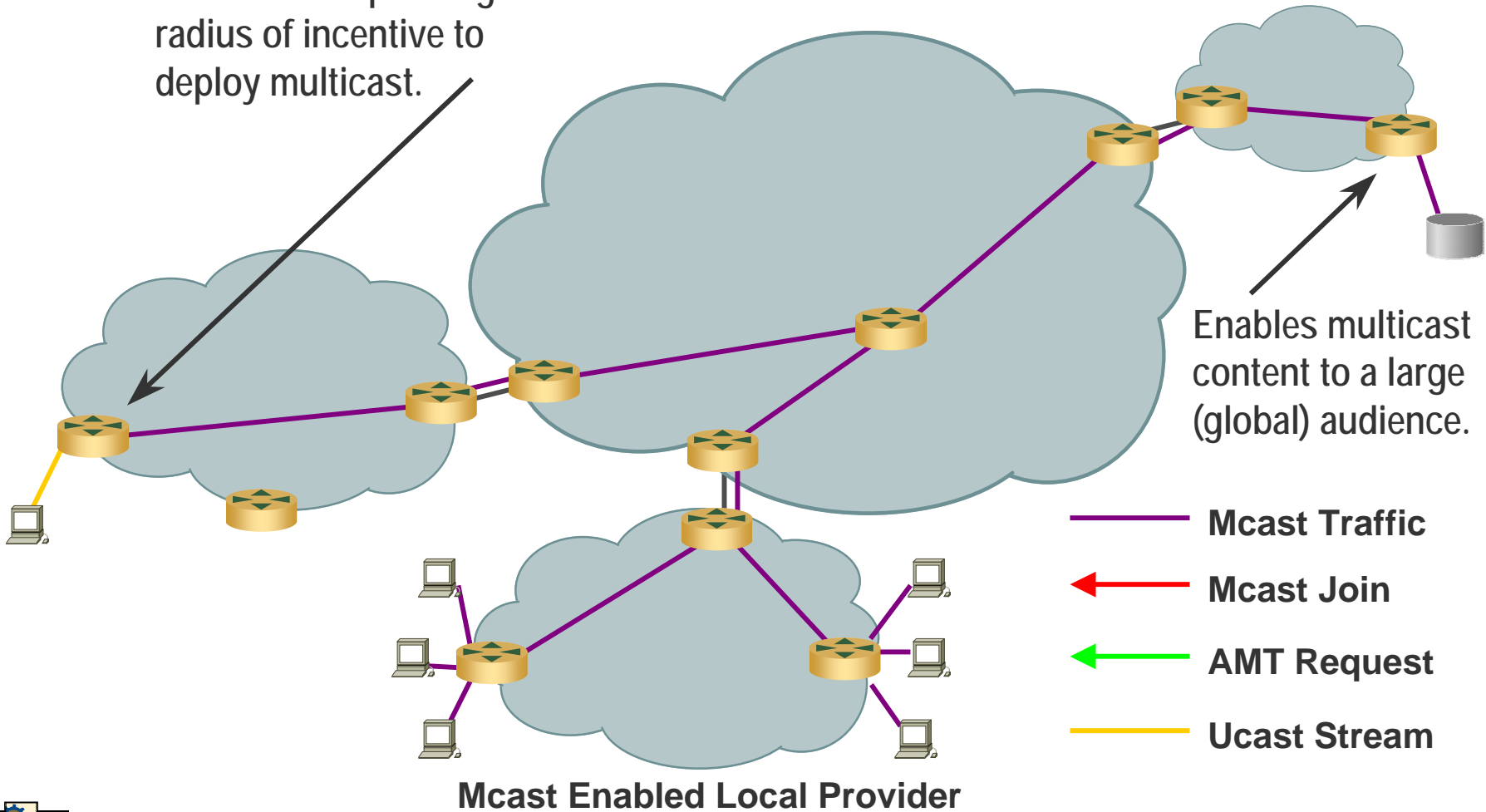

- Mcast Traffic
- ← Mcast Join
- ← AMT Request
- Ucast Stream

Mcast Enabled Local Provider



While Multicast Sleeps...



- **Perfect for one-to-many live content**
 - *But without a large enough audience it was a non-starter in the Internet*
 - *"It's become an enterprise application" ...heard during the break.*
- **Content "distribution" has been dominated with P2P**
 - *But no live p2p solution today*
- **A subscriber-distributed sharing network with enough storage and bandwidth could provide VOD on a massive scale.**
- **A few docs on the scaling and distribution characteristics of P2P networks:**
 - http://www.americafree.tv/rankings/vc_usage.total_hours.post_fit.rank_shift_8.png
 - <http://www.isi.edu/~annc/papers/ChervenakThesisNov94.ps.Z>
 - http://www.isa.its.tudelft.nl/~pouwelse/Bittorrent_Measurements_6pages.pdf

Multicast today



- **Walled Gardens are taking-off globally**
 - *Triple-play networks*
 - *Server Farms*
 - *Financial networks*
- **Global multicast connectivity**
 - *Still growing, but at a much slower-rate*
 - *Still needs to overcome the all-or-nothing barrier*
 - *SSM a must*
 - *ISC will continue to spread the love.*



Thank you!

shep@cisco.com

www.cisco.com

www.isc.org